

Mobility and Rehabilitation



350kg & 250kg Bariatric Walkers



“A fantastic innovation providing mobility!”



The Nybro Mobiliser Walker is a walking frame designed for the specific needs of Bariatric patients. It has a safe capacity for patients weighing up to 350kg.

The device is intended for use with the assistance of occupational therapists for rehabilitation of bariatric patients that may require physical therapy.

The height and width of elbow supporting armrests are adjustable to suit the ergonomic requirements of the patient.



350kg Bariatric Walker expanded for use.

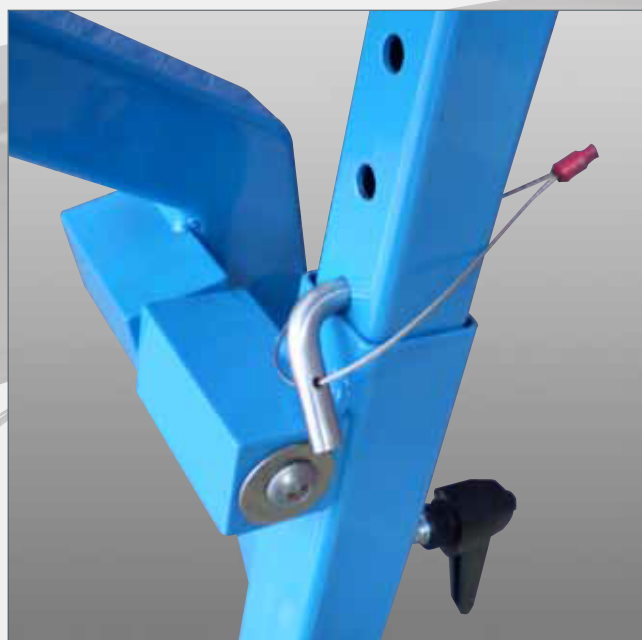

Adjustable height with locking mechanism.

The device is built from high strength materials and has surface finishes that are easy to keep hygienically clean. When not in use, the device can be folded for compact storage. The vinyl arm rest covers are removable to allow for cleaning or replacement.

The device is fitted with heavy duty swivel casters and two rear casters that are fitted with breaks. The fasteners are specially designed and machined to be fitted with a clean unnoticeable finish, removing the risk of injury to the patient.

Nybro 350kg Bariatric Walker



Our Bariatric walkers folding feature is great for easy storage.

Key Features

350kg weight capacity	●
Folding for compact storage	●
Adjustable width arm rests	●
Extensive height adjustments	●
Easy removal of arm rest covers for cleaning	●

Technical Specifications

Frame manufactured from high strength structural steel with attractive powder coating zinc plating finish	●
Heavy duty industrial castors	●
Hygienic Stainless Steel handles and arm rest	●
EPDM Foam Rubber arm rest cushions	●

350kg Bariatric Walker Specifications

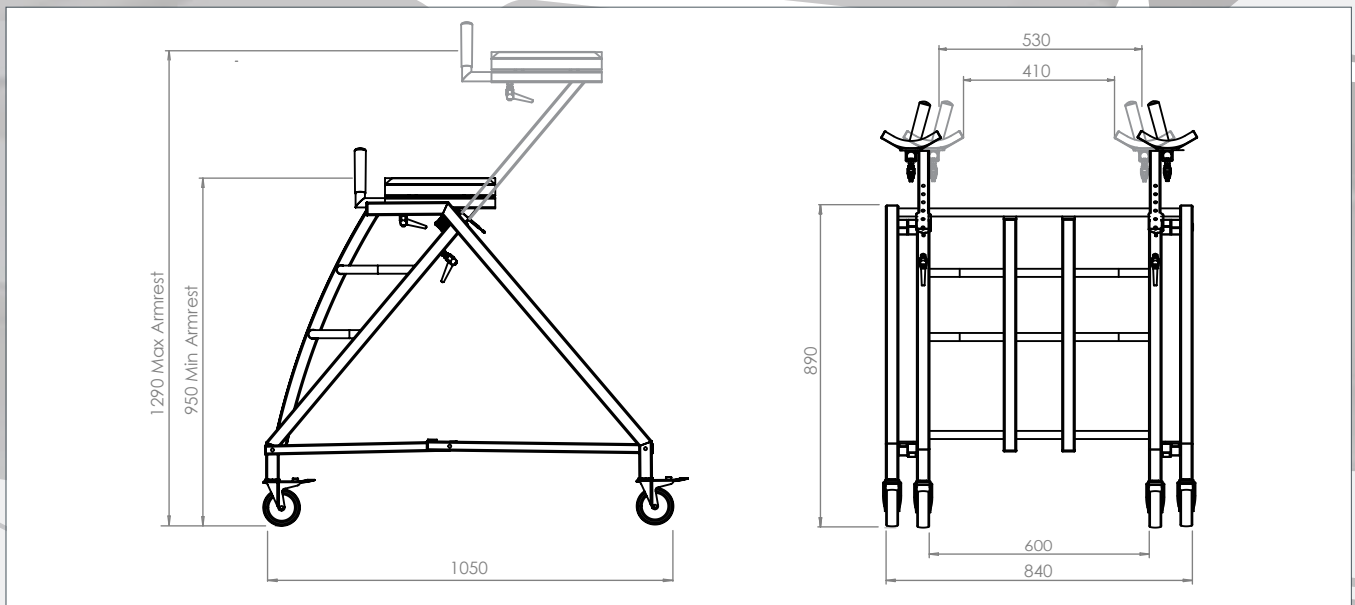

Nybro 250kg Bariatric Walker

Key Features

250kg weight capacity	●
Folding for compact storage	●
Adjustable width arm rests	●
Extensive height adjustments	●
Easy removal of arm rest covers for cleaning	●

Technical Specifications

Frame manufactured from high strength structural steel with attractive powder coating zinc plating finish	●
Heavy duty industrial castors	●
Hygienic Stainless Steel handles and arm rest	●
EPDM Foam Rubber arm rest cushions	●



Nybro's 250kg walker with extended arms ready for use.

250kg Bariatric Walker Specifications

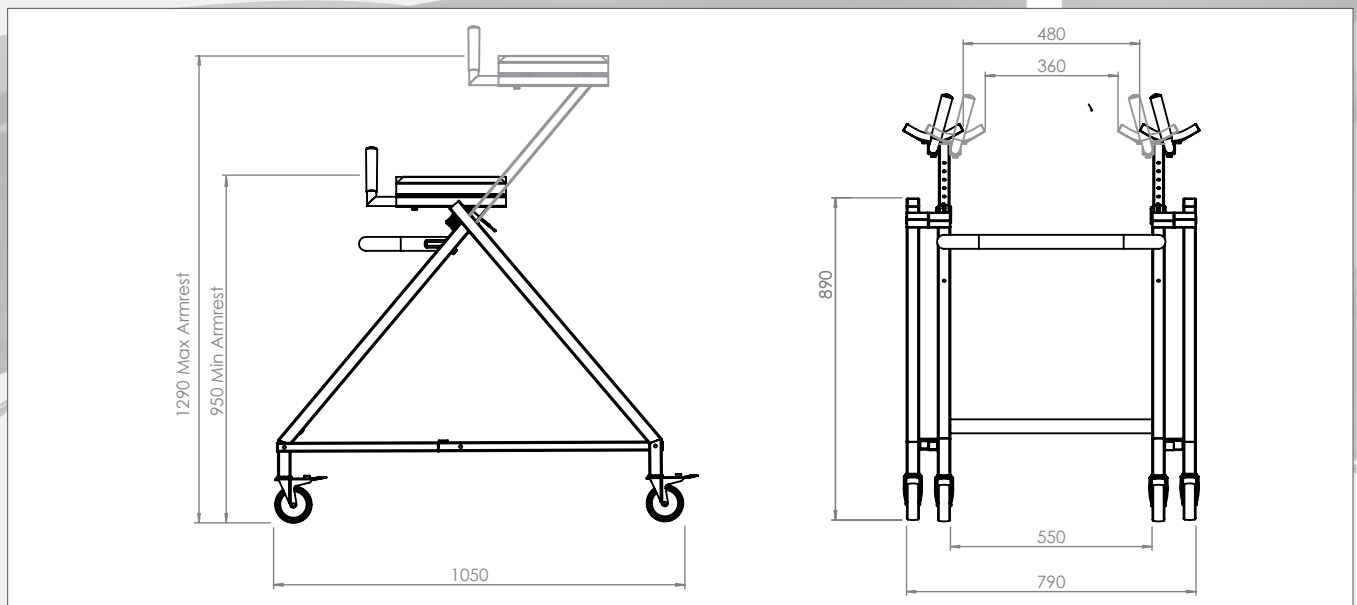

Notes:

Applicable Patents & Registered Design Numbers Held at Nybro



PO Box 1758
Buderim Q 4556

Tel: +61 (0)7 5345 9770

nybro@nybro.com.au
www.nybro.com.au